

TGL

TGL Series Low Speed Sound-Proof Granulators

1000

TGL TGL Series Low Speed Sound-Proof Granulators

TGL

属于无筛网型塑胶回收粉碎机。20~28 rpm低速运转，齿端式刀具设计，专门设计用于粉碎各类硬性及脆性塑胶之不良产品，次品的机边粉碎回收利用；尤其适合粉碎回收PC、尼龙、ABS等硬质水口料。具有转速低，扭矩大，噪音低，产生粉尘少，操作简便的优点，而且具备产品粉碎颗粒均匀，粉碎效果极佳，设备运转中无过热现象，使用寿命长等特点。

As Low Speed Sound-Proof Gran

Product Structure Diagram

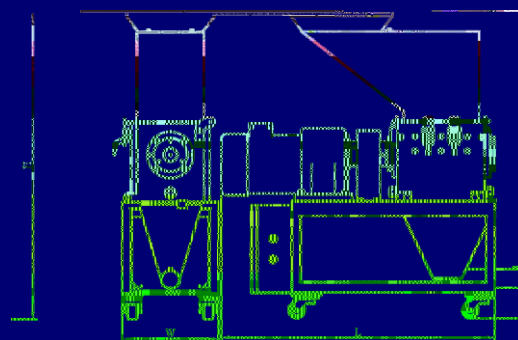

Specification Sheet

Model	TGL-2000S-L	TGL-2000S-H	TGL-3000S-L	TGL-3000S-H	TGL-5000S-L	TGL-5000S-H
-------	-------------	-------------	-------------	-------------	-------------	-------------

● 饮料式回收系统流程图 Blown Material Type Recovery System Flowchart



● 新式料比例回收系统流程图 The Data of The Proportion of The New Recovery System Flow Chart

